

# Press Brake

Tool & Supply, Inc  
 Ph: 888-272-5334  
 Fax: 847-202-9638

## Shear Blade Specs

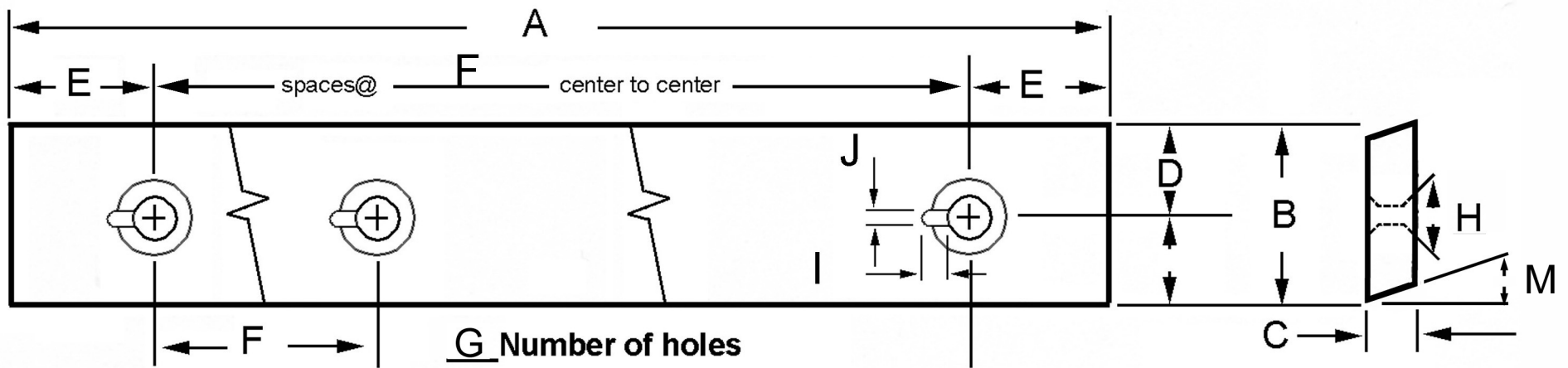
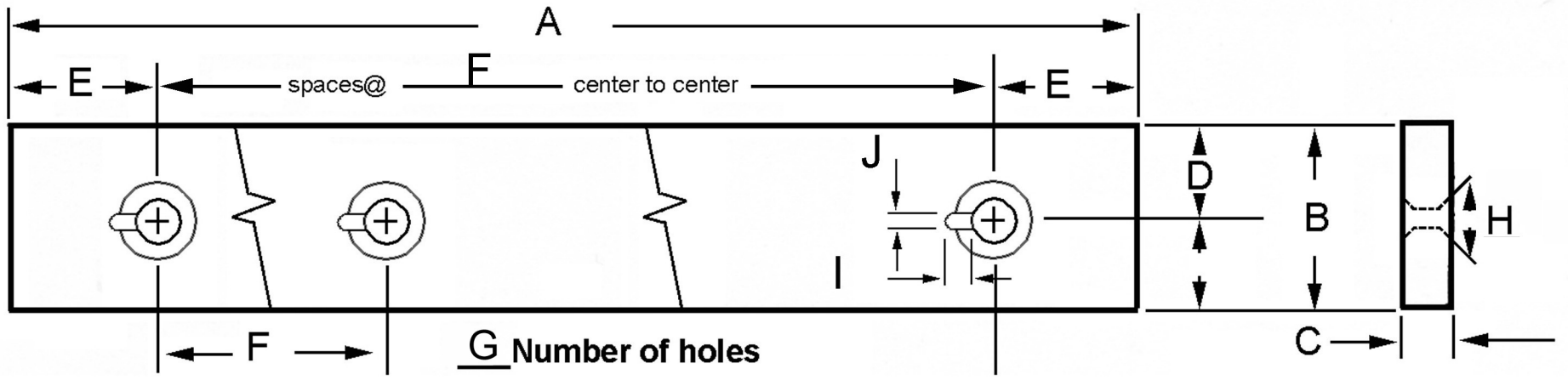

- |                        |          |                         |       |
|------------------------|----------|-------------------------|-------|
| A. Knife length        | _____    | G. Number of holes      | _____ |
| B. Knife width         | _____    | H. Angle of countersink | _____ |
| C. Knife thickness     | _____    | I. Keyway length        | _____ |
| D. Hole center to back | _____    | J. Keyway thickness     | _____ |
| E. End to first hole   | _____    | K. Hole diameter        | _____ |
| F. Center to center    | _____    | L. Drilled or tapped    | _____ |
|                        | M. Angle |                         | _____ |

### Machine Specifications

Manufacturer \_\_\_\_\_  
 Model \_\_\_\_\_  
 Capacity \_\_\_\_\_

### Application

Materials being sheared  
 % mild steel \_\_\_\_\_  
 % stainless steel \_\_\_\_\_  
 Max. thickness Mild steel \_\_\_\_\_  
 Max thickness stainless steel \_\_\_\_\_